



**Powerwise Ink Pumps**  
 2700 West 21st Street  
 Erie, PA 16506  
 United States  
 Tel: +1-814-833-3715  
 Fax: +1-814-838-3850  
[www.powerwise.com](http://www.powerwise.com)

**AIR DRIVEN, DOUBLE DIAPHRAGM PUMP MANUAL**

Congratulations on purchasing one of the most durable and versatile pumps made anywhere. With the proper installation and maintenance the pump will provide years of great performance.

READ THESE WARNINGS AND SAFETY PRECAUTIONS PRIOR TO INSTALLATION OR OPERATION. FAILURE TO COMPLY WITH THESE INSTRUCTIONS COULD RESULT IN PERSONAL INJURY AND OR PROPERTY DAMAGE. RETAIN THESE INSTRUCTIONS FOR FUTURE REFERENCE.

**▲WARNING** Before placing the pump in service make certain it is compatible with the fluid being pumped. Changes of temperature, concentrations or combinations of chemicals may vary resistance of material. Always consult Material Safety Data Sheets and Engineering Resistance Tables for chemical compatibility.

- Be certain all operators of this equipment have been trained for safe working practices.

**▲DANGER HAZARDOUS MATERIAL:** Protective eye wear and clothing should be used whenever pumping hazardous or toxic fluids.

- If a diaphragm ruptures, the pumped product can enter the air side of the pump and exit through the air exhaust. When the fluid is hazardous pipe exhaust away from the work area and personnel.
- When the fluid source is at a higher level than the pump (flooded suction), the exhaust should be piped to a higher level than the fluid source to prevent spills caused by siphoning if a diaphragm rupture should occur.

**▲DANGER HAZARDOUS PRESSURE:** Do not clean or service pump, hoses or dispensing valves when the system is pressurized - serious injury may result.

- Disconnect air supply line and relieve pressure from the system prior to disassembly.

**▲DANGER STATIC WARNING:** Pumping of flammable materials may cause a build-up of a static charge within the electrically non-conductive pumps. Static spark can cause explosion resulting in severe injury or death. Ground pump and pumping systems when pumping flammable products or when used in a location where surrounding atmosphere is conductive to spontaneous combustion. Optional conductive non-metallic models are available when grounding is necessary. Use grounding lugs and always connect to a good ground source.

- Secure pump, connections and all contact points to avoid vibrations and generation of contact or static spark. Periodically verify continuity of electrical path to ground with an ohmmeter from each component.
- Consult local building codes and electrical codes for specific grounding requirements.
- Use hoses incorporating a static wire.
- Use proper ventilation
- Keep flammables away from heat, open flames and sparks.
- Keep containers closed when not in use.

**▲WARNING** Maximum temperatures are based on mechanical stress only. Certain chemicals will significantly reduce maximum safe operating temperature. Consult engineering guides for chemical compatibility and temperature limits.

- Always use minimum air pressure when pumping at elevated temperatures.

**▲WARNING** Excessive air pressure can cause pump damage, personal injury or property damage.

**▲WARNING** Pump must be reassembled properly after maintenance.

**▲CAUTION** Do not use the pump for the structural support of the piping system. Be certain the system components are supported to prevent stress on the pump parts.

- Flexible connections will avoid damage to piping due to vibration.

<b>▲DANGER</b>	= Immediate hazards which will result in severe personal injury or death.
<b>▲WARNING</b>	= Hazards or unsafe practices which could result in severe personal injury, death or substantial property damage.
<b>▲CAUTION</b>	= Hazards or unsafe practices which could result in minor personal injury, product or property damage.



**Powerwise Ink Pumps**  
2700 West 21st Street  
Erie, PA 16506  
United States  
Tel: +1-814-833-3715  
Fax: +1-814-838-3850  
[www.powerwise.com](http://www.powerwise.com)

### INSTALLATION

**NOTICE:** Re-torque fasteners prior to use. Refer to torque requirements listed in maintenance manual and attached to pump

1. A lube-free, clean, dry, compressed air source (or any nonflammable, compressed gas) is recommended. Use a filter that is capable of filtering out particles larger than 50 microns.
2. All pumps should be mounted in an upright position with the exception of the 1/4" models which may be rotated 360° to suit the application.
3. When particles exceed the maximum particle specification of the pump or are sharp enough to cut elastomers install a particle fluid filter on the fluid suction line.
4. Fluid suction lines and air exhaust lines should never be smaller than specified pipe size of pump.
5. Apply PTFE tape to threads upon assembly to prevent leakage.
6. Never use pipe dope on air line connections.
7. Never use collapsible tube on fluid inlet.
8. Do not exceed 10 ft-pounds of torque on plastic pipe threads.
9. If changing to a different application reconfirm compatibility of fluid.

### SUBMERGED APPLICATIONS

1. Fluid must be compatible with fasteners and with intermediate material.
2. Pipe exhaust above the level of the fluid.

### HIGH VISCOSITY APPLICATIONS

1. Position the pump close to or below the level of the fluid source.
2. Suction lines should be increased in size - up to three times the size of the inlet manifold. Dual manifolds may be used when available.
3. Start the pump slowly using a valve on the air line.

### LOW TEMPERATURE and UV EXPOSURE

1. Polypropylene tends to embrittle at freezing temperature. Pump must be insulated or heated, otherwise use pumps with different materials of construction.
2. If excessive icing occurs at the pump exhaust, air source must be dried using mechanical means or through the introduction of ethyl alcohol in the air line.
3. UV rays will damage polypropylene pumps, either shroud the pumps from UV rays or use pumps with UV stabilized materials.

### GENERAL MAINTENANCE

1. Check periodically for product or air leakage. Tighten any joint where leakage is occurring.
2. When pumping hazardous or toxic materials, diaphragms should be replaced at regularly scheduled intervals based upon pump usage.

3. In freezing temperatures, the pump must be completely drained when idle.
4. When pumping highly abrasive fluids reduce discharge flow rate or reduce air pressure to prolong diaphragm life.
5. If you are pumping a material that will settle or compact the pump must be flushed before shut down.

### TROUBLE SHOOTING

#### AIR IS APPLIED TO PUMP BUT PUMP IS NOT STARTING

1. Clean filters and debris from all fluid lines
2. Make sure all valves on fluid lines are open.
3. Inspect diaphragms for rupture.
4. Air pressure must not be below 20 psi (1,3 bar)

#### PUMP IS PUMPING BUT NOT PRIMING

1. Check all suction line connections for leakage.
2. Inspect check valves for wear or debris.
3. Suction lift specifications may be exceeded.
4. If fluid is viscous use larger suction lines.

#### LEAKAGE

1. Retorque all fasteners to specified torque requirements.
2. Replace o-rings.
3. Inspect diaphragms for rupture

#### LOW FLOW RATE

1. Confirm air pressure and air capacity at the air valve as required.
2. Check for leaks in suction line or obstructions in lines.
3. If fluid is viscous use larger suction lines.
4. Viscosity of fluid may have increased if temperature is lower.

#### AIR IN DISCHARGE LINES

1. Check for leaks in suction lines.
2. Inspect diaphragms for rupture.

#### ERRATIC CYCLING

1. Inspect check valve seats for debris.
2. Inspect fluid lines for debris.
3. Automatic valves must be properly functioning.
4. Viscosity of product may be changing.

#### PREMATURE DESTRUCTION OF WETTED COMPONENTS

1. If fluid is abrasive slow down pump or increase size of pump
2. Filter fluid for sharp objects.
3. Make sure fluid is compatible with wetted materials.

# 1/4" CLASSIC PERFORMANCE MAINTENANCE MANUAL

## CHECK VALVE, GASKET AND O-RING MAINTENANCE

1. Flush and neutralize the pump to be certain all corrosives or hazardous materials are removed prior to any maintenance. This procedure should always be followed when returning pumps for factory service also. Remove suction, discharge and air supply lines.
2. Remove the 1/4-20 nuts (28) and slide the six cap screws (27) that hold the pump together out of the pump. Remove the #8 screws (5) from the left and right manifold plates (1, 19) and inspect the gaskets (2). The suction (or lower) check valves are an integral part of the left and right chambers and should not be dismantled. If replacement of the valve seats is necessary, the left and right chambers (6, 18) which contain the valves must be replaced. The upper discharge disks (3) are not sealed into the chambers and may be inspected for wear. If any components are worn or scratched, replace. Note: Due to the distortion of gaskets under pressure, gaskets may need to be replaced after pump has been disassembled to assure a positive seal
3. To inspect manifold tube o-rings (17) remove right chamber.
4. Both diaphragms (9) can be inspected after removing the left and right chamber. If diaphragms appear worn or ruptured go to step 7. If diaphragms do not need replacing, proceed with steps 5 and 6.
5. To reassemble: Insert the discharge valve disks into place. Press gaskets into grooves in chambers.

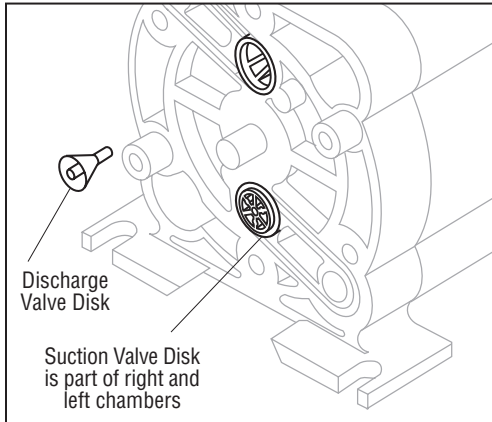

6. Align left and right manifolds on the bosses of the chambers. Secure to each chamber with the ten #8 screws. **Tighten to 12 ft-lbs (16,3 NM)**. Slide left chamber tubes through intermediate. Position o-rings on the end of the tubes. Lubricate o-rings and right chamber holes. Slide a flat washer (26) onto each of the six capscrews and insert through the entire assembly. Secure with a flat washer (26) and a tension washer (29) under each nut. **Tighten to 5 ft-lbs (6,8 NM). Apply torque evenly.**

## DIAPHRAGM MAINTENANCE

7. Remove outer diaphragm plates (7) by holding one diaphragm plate and twisting off the other plate.
8. The diaphragm o-ring (8) is used only with PTFE diaphragms. Replace diaphragms if ruptured or worn. Inspect inner diaphragm plates (10). If diaphragm rod needs replacing go to step 10.

9. If no further inspection is necessary reassemble inner diaphragm plates and diaphragms onto stud of outer diaphragm plates and screw each assembly into diaphragm rod. (Make sure optional diaphragm o-ring is in position in the o-ring groove on either side of the intermediate if using PTFE diaphragms. When positioning PTFE diaphragms make sure that the concave side is facing the wet ends of pump.) **Tighten outer diaphragm plates to 40 in-lbs (4,5 NM)**. Reassemble pump according to steps 5 and 6.

## AIR VALVE AND DIAPHRAGM ROD MAINTENANCE

10. To remove the diaphragm rod twist the two rod halves apart by using a 7/16" wrench on the flats at the end of each half. Pull each half out of the pump. Inspect for corrosion.
11. To inspect diaphragm rod lip seals (14) remove the two self tapping screws (12) from the retaining plates (13). Gently remove lip seals and inspect for damage. To reassemble, lubricate diaphragm rod lip seals (14) and insert into bore with the u-cup portion facing inward. Note: Since the diaphragm rod passes through the spring clip assembly (23), spring clip assembly must be removed prior to reinsertion of the diaphragm rod into bore in intermediate.
12. To remove spring clip assembly firmly pull air valve plug (25) from pump.
13. Inspect spring clip assembly and shuttle (22) for damage. Surface of intermediate around air ports and flat surface of shuttle must be smooth, no scratches or debris. Replace or clean if necessary.
14. Attach retainer plate with flat surface toward lip seals. Do not over tighten self tapping screws.
15. To reinsert diaphragm rod halves, drop shuttle into intermediate over ports. Groove in shuttle should be aligned vertically in pump and should face outward. Insert spring side of spring clip assembly into groove in shuttle. At this point the assembly is not affixed to anything. Press down as shown below to insert long half of diaphragm rod (16) through spring clip assembly and position under spring ends.

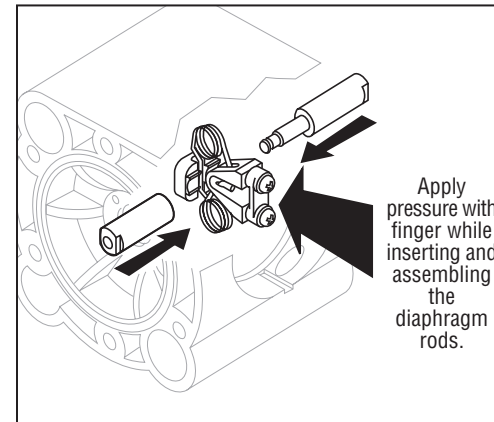

16. While continuing to apply pressure to spring clip assembly, screw short half of diaphragm rod (11) into long half.
17. Follow instructions for assembly of diaphragms in step 9. Final tightening of diaphragm rod will occur when outer diaphragm plates are tightened.
18. Make sure valve plug o-ring (21) is well lubed, position o-ring and press air valve plug into the intermediate making sure that tab and indentation are aligned. If o-ring is not well lubricated, it will not permit reinsertion.

19. Follow procedure for final assembly of pump in step 6.

## SPECIFICATIONS

### CAPACITY:

Adjustable . . . 0 to 4.3 GPM (16,3 liters/min.)

### MAXIMUM TEMPERATURE:

KN-025 Model . . . . . 200°F (93°C)

Other Models . . . . . 150°F (66°C)

### MAXIMUM AIR PRESSURE:

All Models . . . . . 100 PSI (6,8 bar)

### DRY LIFT:

Other Models . . . . . 17 ft. (5 meters)

### WEIGHT:

KN-025 Model . . . . . 7 lbs. (3,2 kg.)

Other Models . . . . . 5 lbs. (2,3 kg.)

**Maximum Solids:** . . . . . 1/16" or (1,6 mm)

### AIR SUPPLY:

Inlet . . . 1/4" NPT Female (BSP Compatible)

Outlet . . . . . 1/4" NPT Female

**Fluid Inlet/Discharge:** . . . . . 1/4" NPT

\* Geolast properties are similar to that of Nitrile (Buna-N)

## DIMENSIONS

Dimensions in inches and (mm)

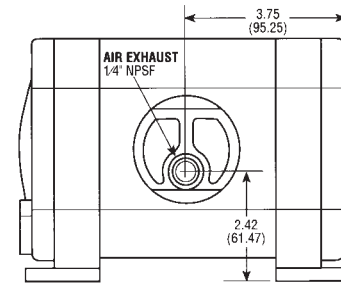

Rear View

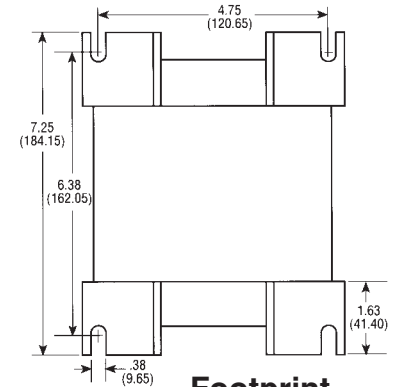

Footprint

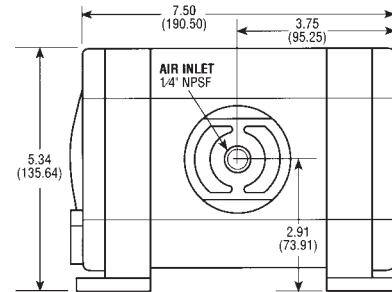

Front View

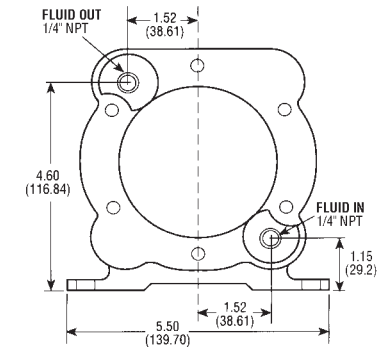

Side View

## Typical Installation

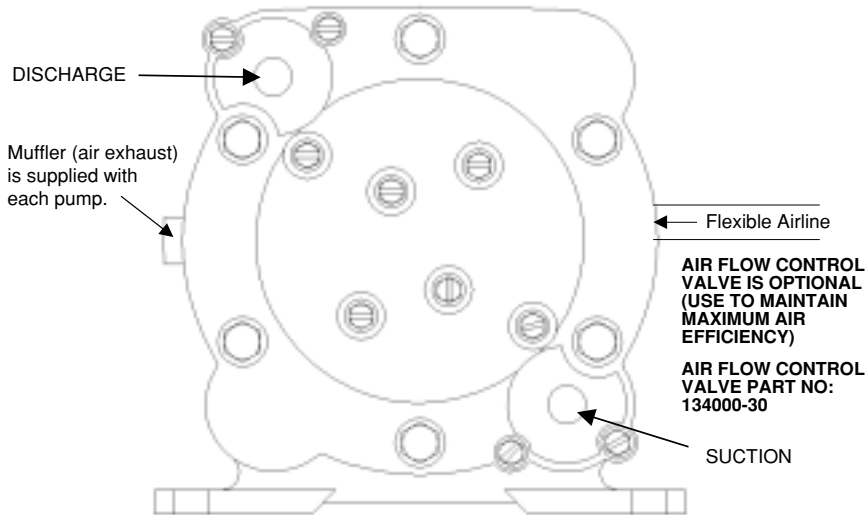

**DO NOT USE AIR LINE LUBRICATION**

## PERFORMANCE CURVE

(Based on water-flooded suction)

